

## Pinnacle™ 7251

### Intelligent Laser Smoke Detector



### Features

- Ultra-high-sensitivity capability
- On-board drift compensation
- Transient rejection algorithms
- Environmental tracking
- Wide sensitivity range
- Rotary address switches
- Analog communications
- Sleek, low-profile design
- Low standby current
- Microprocessor design
- Superior EMI protection

### Description

Pinnacle™ model 7251 is an intelligent, laser-based photoelectric smoke detector featuring extensive on-board signal processing capabilities designed to improve smoke response. Pinnacle also features a patented smoke sensing chamber, designed to amplify signals from smoke, but diminish stray internal reflections. By using a laser diode instead of a standard LED light source into the sensing chamber, Pinnacle is able to achieve sensitivities from 0.02% to 2% per foot obscuration.

The detectors' extensive software processing includes multi-alert drift compensation, internal self diagnostics, and superior transient signal rejection algorithms to produce unprecedented stability at ultra high sensitivities, over the complete temperature range.

Because Pinnacle is base-compatible with all other 200 Series detectors, system designers can seamlessly mix it with other standard detection technologies thereby reducing overall cost.

Other advantages of Pinnacle over other high sensitivity detection methods are:

- Pinpoint identification of the fire location resulting from addressability
- No delay in response because of smoke dilution or smoke transportation time as in aspirated systems
- Complete supervision of wiring and detector

Pinnacle is designed to protect valuable assets and operations where systems must remain online at all times. Many sensitive areas cannot tolerate even small amounts of smoke. Some ideal applications for Pinnacle include:

- Telecommunications switching facilities
- Cellular telephone infrastructure
- Integrated circuit fabrication facilities
- Computer rooms
- Traffic control centers
- Clean rooms

### Installation

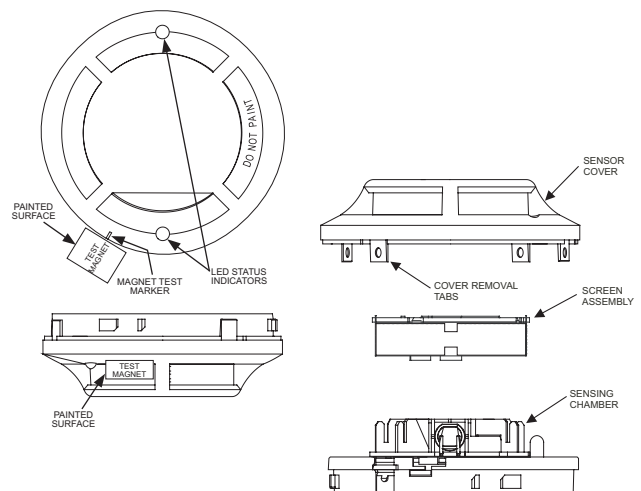

## Specifications

Voltage Range
15-32 volts DC peak
Standby Current (max. avg.)
230uA @ 24 VDC (without communication), 330uA @ 24 VDC (one communication every 5 sec. with LED enabled)
LED Current (max.)
6.5 mA @ 24 VDC (on)
Height
1.66" (4.2 cm)
Diameter
4.0" (10.2 cm)
Shipping Weight
5.6 oz. (159 g)
Velocity Range
0 - 4000 fpm (0 to 20.3 m/s)

Operating Humidity Range
10% - 93% noncondensing
Operating Temperature Range
32° to 100° F (0° to 38° C)
Self Diagnostics
Initiated by control panel Activated by test magnet
Smoke Sensitivity
9 levels: 0.02, 0.03, 0.05, 0.10, 0.20, 0.50, 1.00, 1.50, 2.00%/ft. obscuration (0.06, 0.10, 0.16, 0.33, 0.66, 1.65, 3.24, 4.85, 6.41%/m obscuration)
Drift Compensation
High sensitivity maintenance alert signal Low sensitivity maintenance alert signal Maintenance urgent signal

## Ordering Information

Model	Description
7251	Low Profile Intelligent Laser Smoke Detector
<b>200 Series Bases</b>	
B501	4" Flangeless Mounting Base
B210LP	6" Flanged Mounting Base
B224RB	Relay Base
B224BI	Isolator Base
B200SR	Standard Sounder Base

Add suffix "A" for Canadian ULC listed model.